

## A 0.65V/1μA Nanopower Voltage Detector with Dual Outputs

### FEATURES

- ◆ Nanopower Voltage Detector in Single 4 mm<sup>2</sup> Package
- ◆ Ultra Low Total Supply Current: 1μA (max)
- ◆ Supply Voltage Operation: 0.65V to 2.5V
- ◆ Preset 0.78V UVLO Trip Threshold
- ◆ Internal ±10mV Hysteresis
- ◆ Resettable Latched Comparator
- ◆ Complimentary and Open-drain Comparator Outputs
- ◆ Separate Comparator Output Supply Pin

### DESCRIPTION

The TS12001 voltage detector combines a 0.58V reference and a comparator with resettable comparator latch in a single package. The TS12001 operates from a single 0.65V to 2.5V power supply and consumes less than 1μA total supply current. Optimized for ultra-long life operation, the TS12001 expands Touchstone's growing "NanoWatt Analog™" high-performance analog integrated circuits portfolio.

The voltage detector exhibits a preset UVLO threshold voltage of 0.78V (typ) or can be set to other threshold voltages with two external resistors. The comparator exhibits ±10mV of internal hysteresis for clean, chatter-free output switching. The TS12001 also offers both push-pull and open-drain outputs. When compared against similar products, the TS12001 offers a factor-of-2 lower power consumption and at least a 33% reduction in pcb area.

The TS12001 is fully specified over the -40°C to +85°C temperature range and is available in a low-profile, 10-pin 2x2mm TDFN package with an exposed back-side paddle.

### APPLICATIONS

- Power-Fail Indicator
- Low-Battery Detection
- Battery-Backup Detection
- CPU, Microprocessor, and Logic Reset Controller
- Battery-powered Systems

### TYPICAL APPLICATION CIRCUIT

A Nanopower 1.8V Core System Voltage Detector

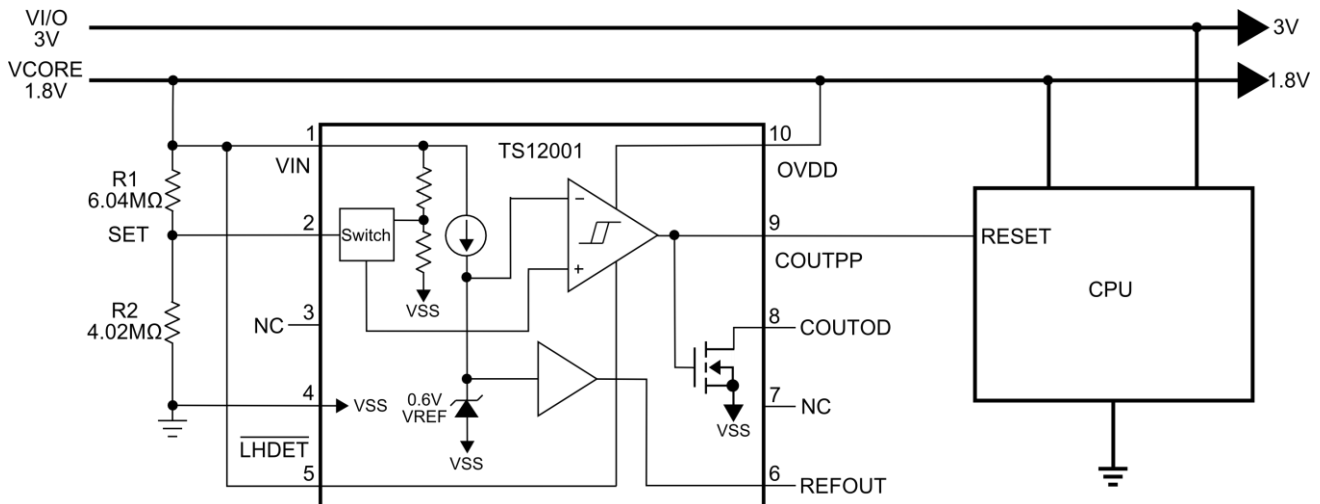

The Touchstone Semiconductor logo and "NanoWatt Analog" are registered trademarks of Touchstone Semiconductor, Incorporated.

## ABSOLUTE MAXIMUM RATINGS

Supply Voltage ( $V_{IN}$ to $V_{SS}$ )	.....+2.75V	Output Current	
Supply Voltage ( $OV_{DD}$ to $V_{SS}$ )	.....+2.75V	COUTPP, COUTOD	.....20mA
Input Voltage		Short-Circuit Duration	
SET	..... $V_{SS} - 0.3V$ to $V_{IN} + 0.3V$	(REFOUT, COUTPP, COUTOD)	.....Continuous
LHDET	..... $V_{SS} - 0.3V$ to +5.5V	Continuous Power Dissipation ( $T_A = +70^\circ C$ )	
Output Voltage		10-Pin TDFN (Derate at 13.48mW/ $^\circ C$ above +70 $^\circ C$ )	..... 1078mW
REFOUT	..... $V_{SS} - 0.3V$ to $V_{IN} + 0.3V$	Operating Temperature Range	..... -40 $^\circ C$ to +85 $^\circ C$
COUTPP	..... $V_{SS} - 0.3V$ to $OV_{DD} + 0.3V$	Junction Temperature	.....+150 $^\circ C$
COUTOD	..... $V_{SS} - 0.3V$ to +5.5V	Storage Temperature Range	..... -65 $^\circ C$ to +150 $^\circ C$
		Lead Temperature (Soldering, 10s)	..... +300 $^\circ C$

Electrical and thermal stresses beyond those listed under “Absolute Maximum Ratings” may cause permanent damage to the device. These are stress ratings only and functional operation of the device at these or any other condition beyond those indicated in the operational sections of the specifications is not implied. Exposure to any absolute maximum rating conditions for extended periods may affect device reliability and lifetime.

## PACKAGE/ORDERING INFORMATION

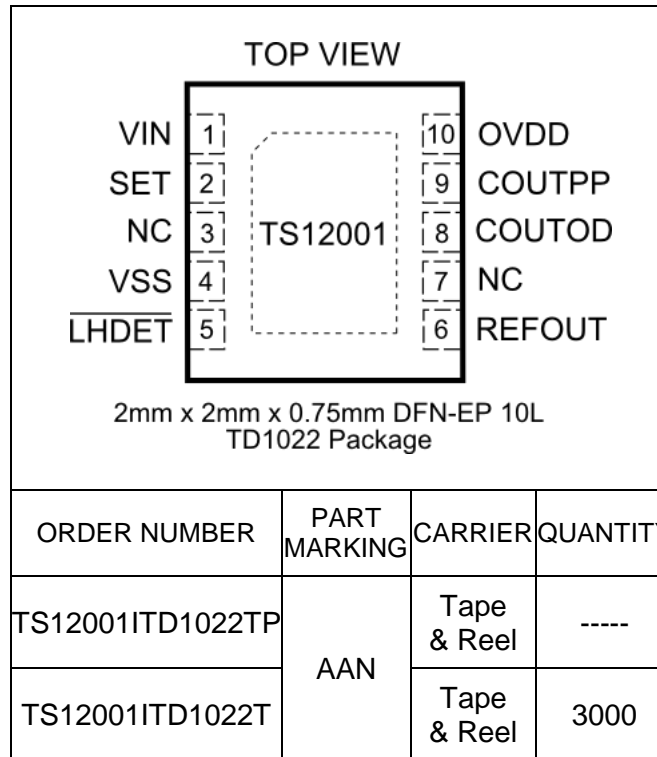

**Lead-free Program:** Touchstone Semiconductor supplies only lead-free packaging.

Consult Touchstone Semiconductor for products specified with wider operating temperature ranges.

## ELECTRICAL CHARACTERISTICS

$V_{IN} = 0V_{DD} = 0.8V$ ;  $V_{SS} = 0V$ ;  $V_{SET} = V_{SS}$ ;  $V_{COUTPP} = HiZ$ ;  $V_{COUTOD} = HiZ$ ;  $T_A = -40^{\circ}C$  to  $+85^{\circ}C$ , unless otherwise noted. Typical values are at  $T_A = +25^{\circ}C$ . See note 1.

PARAMETER	SYMBOL	CONDITIONS	MIN	TYP	MAX	UNITS	
Supply Voltage	$V_{IN}$		0.65		2.5	V	
Supply Current	$I_{IN}$	REFOUT = open	$T_A = +25^{\circ}C$ $-40^{\circ}C \leq T_A \leq 85^{\circ}C$		0.8 1	$\mu A$	
UVLO Output Driver Supply Voltage	$OV_{DD}$		0.65		2.5	V	
Output Driver Supply Current	$I_{ODD}$				0.1	$\mu A$	
Preset UVLO Trip Point		$V_{IN}$ falling until COUTPP switches LOW	725	761	797	mV	
		$V_{IN}$ rising until COUTPP switches HIGH	743	781	818		
SET Trip Point		$V_{SET}$ falling until COUTPP switches LOW	$T_A = +25^{\circ}C$		540	567	595
			$-40^{\circ}C \leq T_A \leq 85^{\circ}C$		534		604
		$V_{SET}$ rising until COUTPP switches HIGH	$T_A = +25^{\circ}C$		560	587	615
			$-40^{\circ}C \leq T_A \leq 85^{\circ}C$		550		620
SET Trip Response Time		$V_{SET}$ rising		13		$\mu s$	
		$V_{SET}$ falling		10			
Preset UVLO Trip Hysteresis				$\pm 10$		mV	
SET Enable Threshold		See Note 2	90			mV	
SET Input Leakage		$V_{SET} = V_{SS}$ ; $V_{SET} = V_{IN}$			20	nA	
LHDET Input Low Voltage	$V_{IL}$	Comparator Latched Output Enabled	$0.78V \leq V_{IN} \leq 1.1V$		0.1	V	
			$1.1V < V_{IN} \leq 2.5V$		0.2		
LHDET Input High Voltage	$V_{IH}$	Comparator Latched Output Disabled	$0.78V \leq V_{IN} \leq 1.1V$		$V_{IN} - 0.1$	V	
			$1.1V < V_{IN} \leq 2.5V$		1		
LHDET Input Leakage		$V_{LHDET} = V_{SS}$ ; $V_{LHDET} = 5.5V$			100	nA	
Reference Output Voltage	$V_{REF}$		$T_A = +25^{\circ}C$		555	577	600
			$-40^{\circ}C \leq T_A \leq 85^{\circ}C$		552		602
Reference Load Regulation		$I_{OUT} = \pm 100nA$			0.5	%	
Output High Voltage	$V_{OH}$	COUTPP; $I_{OUT} = -100\mu A$	$V_{IN} - 0.1$			V	
Output Low Voltage	$V_{OL}$	COUTPP; $I_{OUT} = 100\mu A$			$V_{SS} + 0.1$	V	
Output Low Voltage	$V_{OL}$	COUTOD; $I_{OUT} = 100\mu A$			$V_{SS} + 0.11$	V	
Output Short-Circuit Current,	$I_{SC}$	Sourcing; $V_{COUTPP} = V_{SS}$	0.1			mA	
		Sinking; $V_{COUTPP} = V_{IN}$	0.5			mA	
		Sinking; $V_{COUTOD} = V_{IN}$		1.4			mA
Open Drain Leakage		COUTOD; $V_{COUTOD} = 5V$			20	nA	

**Note 1:** All devices are 100% production tested at  $T_A = +25^{\circ}C$  and are guaranteed by characterization for  $T_A = T_{MIN}$  to  $T_{MAX}$ , as specified.

**Note 2:** A SET voltage above this threshold voltage enables the SET pin voltage to control the comparator output.

## PIN FUNCTIONS

PIN	NAME	FUNCTION
1	VIN	Positive Supply Voltage. Connect a 0.1 $\mu$ F bypass capacitor from this pin to analog VSS/GND.
2	SET	External UVLO Trip Threshold Set Pin. When this pin is set to VSS, the internal preset 0.78V UVLO trip threshold controls the comparator output. When the applied voltage to this pin is higher than 90mV, the SET pin sets the trip threshold and controls the comparator output. If the SET pin is not used, connect the pin to VSS.
3	NC	No Connection
4	VSS	Negative Supply Voltage.
5	$\overline{\text{LHDET}}$	Latch Enable Pin. When $\overline{\text{LHDET}}$ is set HIGH, the outputs of the comparator will toggle normally based on the inputs to the comparator. When $\overline{\text{LHDET}}$ is set LOW and COUTPP is HIGH, COUTPP will remain HIGH despite any changes to the input of the comparator. COUTPP will once again respond to changes to the input when $\overline{\text{LHDET}}$ is toggled HIGH. If COUTPP is initially LOW and the $\overline{\text{LHDET}}$ is then LOW, COUTPP will stay LOW. If a LOW-to-HIGH transition occurs on COUTPP, COUTPP will switch to HIGH and stay HIGH and not respond to any changes at the input. The $\overline{\text{LHDET}}$ pin must always be set to a known state. For unlatched comparator operation, set $\overline{\text{LHDET}}$ to HIGH. The open-drain output (COUTOD) is the inverted version of the COUTPP output.
6	REFOUT	0.58V Reference Output
7	NC	No Connection
8	COUTOD	Comparator Open-Drain Output
9	COUTPP	Comparator Push-Pull Output
10	OVDD	Output Driver Positive Supply Voltage. Connect a 0.1 $\mu$ F bypass capacitor from this pin to analog VSS/GND.
EP	----	Exposed paddle is electrically connected to VSS/GND.

## BLOCK DIAGRAM

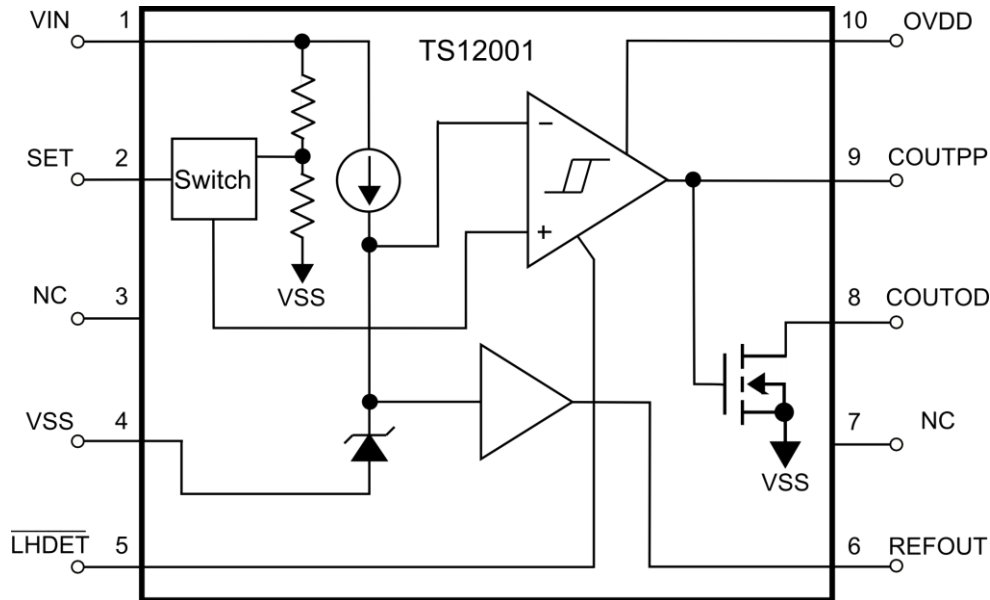

## THEORY OF OPERATION

The TS12001 combines a  $0.58V \pm 4.5\%$  reference and an analog comparator with a resettable comparator latch in a single package. The TS12001 operates from a single  $0.65V$  to  $2.5V$  power supply and consumes less than  $1\mu A$  total supply current. The TS12001 comparator has a push-pull and open-drain output driver. The push-pull output driver is powered from a separate supply voltage,  $OV_{DD}$ . The open-drain output stage allows for easy output voltage level translation as may be required when driving systems powered with a different power supply rail. The analog comparator exhibits  $\pm 10mV$  of internal hysteresis for clean, chatter-free output switching. The internal reference was designed to sink or source up to  $0.1\mu A$  load currents.

The TS12001 has a preset UVLO threshold voltage of  $0.78V$  (typ) or can be set to other threshold voltages with two external resistors where the divided

voltage is applied to the SET pin. When the SET pin voltage is grounded or it is less than approximately  $90mV$ , the internal preset UVLO threshold circuit will control the comparator outputs. If the SET pin is above approximately  $90mV$ , the external voltage divider circuit will control the comparator outputs. The  $0.58V$  reference voltage is tied to the inverting input of the comparator and the output of a switch is connected to the non-inverting input of the comparator. The output of the switch is either the SET voltage or the internal UVLO threshold voltage, depending on whether the SET pin voltage is above or below approximately  $90mV$ . If the switch output is above  $0.58V$ , the push-pull output (COUTPP) will be HIGH and the open-drain output (COUTOD) will be LOW and vice versa. For proper operation, the supply voltage  $V_{IN}$  must be applied before the output driver supply voltage ( $OV_{DD}$ ) is applied.

The TS12001 has a latch enable pin ( $\overline{LHDET}$ ) that

allows the output of the comparator to latch to a HIGH state under certain conditions. If  $\overline{\text{LHDET}}$  is set HIGH, the COUTPP output will switch based on the input to the comparator. When  $\overline{\text{LHDET}}$  is set LOW and COUTPP is HIGH, COUTPP will remain HIGH until  $\overline{\text{LHDET}}$  goes LOW. When COUTPP is initially LOW instead, COUTPP will latch HIGH until a LOW-to-HIGH transition occurs on the COUTPP output. In essence, the  $\overline{\text{LHDET}}$  pin offers a LOW-to-HIGH detection. However,  $\overline{\text{LHDET}}$  must not be left open. The open-drain output, COUTOD, is the inverter version of the COUTPP output. Connect  $\overline{\text{LHDET}}$  to  $V_{\text{IN}}$  for normal operation or to  $V_{\text{SS}}$  for  $\overline{\text{LHDET}}$  enable.

If the SET pin is not used, it cannot be left unconnected and should be tied to  $V_{\text{SS}}$ .

## Comparator

The TS12001 has an internal comparator that can eliminate supply glitches that commonly occur when output transitions occur. In addition, the input exhibits  $\pm 10\text{mV}$  of internal hysteresis in order to insure clean output switching behavior. The outputs can swing to

within 100mV of the supply rails. The COUTPP output can source and sink 0.1mA and 0.5mA of current. The COUTD outputs can sink 1.4mA of current with  $V_{\text{COUTOD}} = 0.78\text{V}$

## Internal Reference

The TS12001's on-board 0.58V  $\pm 4.5\%$  reference voltage can source and sink 0.1 $\mu\text{A}$  and 0.1 $\mu\text{A}$  of current and can drive a capacitive load less than 50pF and greater than 50nF with a maximum capacitive load of 250nF. The higher the capacitive load, the lower the noise on the reference voltage and the longer the time needed for the reference voltage to respond and become available on the REFOUT pin. With a 250nF capacitive load, the response time is approximately 20ms. While also available as a separate pin as REFOUT, the reference is tied internally to the inverting input of the comparator.

## APPLICATIONS INFORMATION

### External Voltage Detector Design

Depending on the battery voltage used and the voltage one wishes to detect, the TS12001 can be designed accordingly. As shown in Figure 1, R1 and R2 can be selected based on the desired voltage to detect. Table 1. provides R1 and R2 resistor combinations for detecting various  $V_{\text{IN}}$  voltages.

$V_{\text{IN}}$ Threshold Voltage(V)	R1(M $\Omega$ )	R2(M $\Omega$ )
0.9	2.2	4.02
1.07	3.32	4.02
1.28	4.75	4.02
1.52	6.49	4.02
1.85	8.66	4.02

**Table 1.** Resistor Combinations for Several  $V_{\text{IN}}$  Threshold Voltages

The design equation for this circuit is shown below. The SET pin voltage ( $V_{\text{SET}}$ ) that will cause a HIGH-to-LOW transition on the output is approximately 580mV. To design the circuit, R1 or R2 can be selected along with the desired battery voltage to detect.

Then, the second resistor value can be evaluated using the voltage divider equation below.

$$R1 = \frac{V_{\text{IN}} \times R2 - V_{\text{SET}} \times R2}{V_{\text{SET}}}$$

### A Nanopower 1.8V Core System Voltage Detector

When power supply rails sag in any system, it is important to alert the CPU. A CPU can be used to detect when I/O or core system voltages sag below a prescribed threshold as shown Figure 2. In this circuit, a 1.8V core system voltage detector is designed around the TS12001 providing a low battery detect signal. R1 and R2 were selected to set a SET voltage at 582mV so that when  $V_{\text{CORE}}$  drops below 1.77V, the TS12001 output transitions to LOW. It is recommended to use 1% resistors for optimal accuracy. The circuit consumes approximately 0.75 $\mu\text{A}$  of current when  $V_{\text{CORE}} = 1.8\text{V}$ .

### PC Board Layout and Power-Supply Bypassing

While power-supply bypass capacitors are not typically required, it is good engineering practice to use 0.1 $\mu\text{F}$  bypass capacitors close to the device's power supply pins. When the power supply impedance is high, the power supply leads are long, or there is excessive noise on the power supply traces. To reduce stray capacitance, it is also good

engineering practice to make signal trace lengths as short as possible. Also recommended are a ground plane and surface mount resistors and capacitors.

## Input Noise

Radiated noise is common in low power circuits that require high impedance circuits. To minimize this effect, all traces between any of the inputs and passive component networks should be made as short as possible.

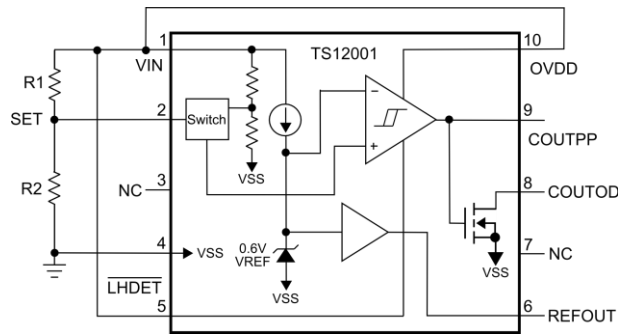

**Figure 1. External Voltage Detector Design Circuit**

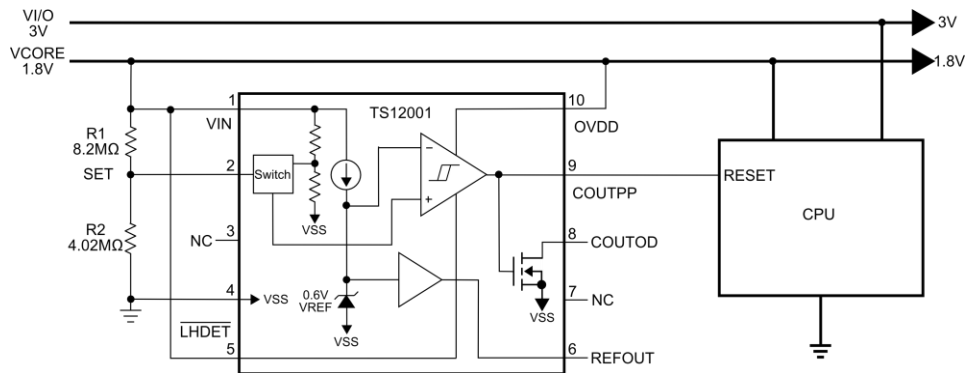
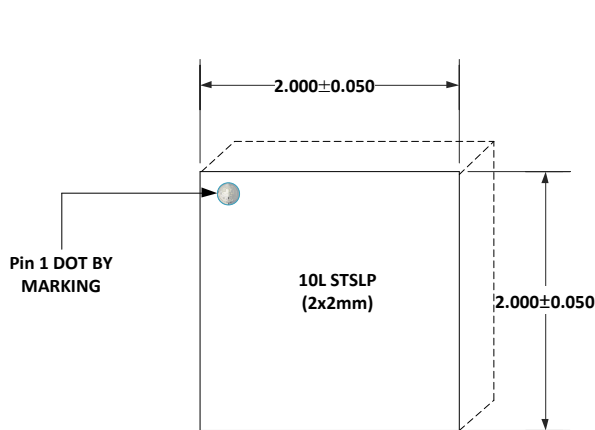

**Figure 2. A Nanopower 1.8V Core System Voltage Detector Circuit**

## PACKAGE OUTLINE DRAWING

### 10-Pin TDFN22 Package Outline Drawing

(N.B., Drawings are not to scale)



**TOP VIEW**

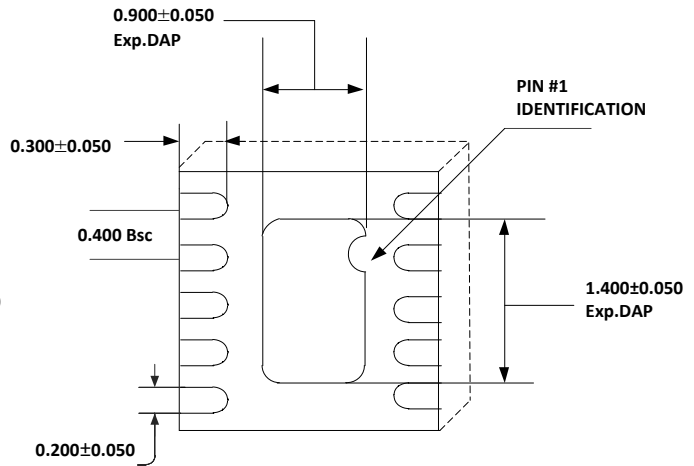

**BOTTOM VIEW**

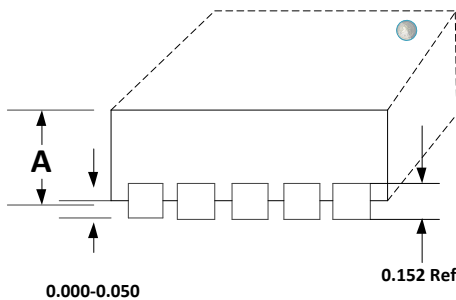

**SIDE VIEW**

**NOTE!**

- All dimensions in mm.
- This part is compliant with JEDEC MO-229 spec

<b>A</b>	MAX.	0.600
	NOM.	0.550
	MIN.	0.500

Information furnished by Touchstone Semiconductor is believed to be accurate and reliable. However, Touchstone Semiconductor does not assume any responsibility for its use nor for any infringements of patents or other rights of third parties that may result from its use, and all information provided by Touchstone Semiconductor and its suppliers is provided on an AS IS basis, WITHOUT WARRANTY OF ANY KIND. Touchstone Semiconductor reserves the right to change product specifications and product descriptions at any time without any advance notice. No license is granted by implication or otherwise under any patent or patent rights of Touchstone Semiconductor. Touchstone Semiconductor assumes no liability for applications assistance or customer product design. Customers are responsible for their products and applications using Touchstone Semiconductor components. To minimize the risk associated with customer products and applications, customers should provide adequate design and operating safeguards. Trademarks and registered trademarks are the property of their respective owners.