

**2.5V 16-Bit Bidirectional Transceiver with 3-State Outputs**

**Product Features**

- The PI74VCX family is designed for low voltage operation  
 $V_{DD} = 1.8V$  to  $3.6V$
- 3.6V I/O Tolerant Inputs and Outputs
- Supports Live Insertion
- Balanced output drive,  $\pm 24mA$
- Uses patented Noise Reduction Circuitry
- Typical  $V_{OLP}$  (Output Ground Bounce)  
 $< 0.6V$  at  $V_{DD} = 2.5V$ ,  $T_A = 25^\circ C$
- Typical  $V_{OHV}$  (Output  $V_{OH}$  Undershoot)  
 $< -0.6V$  at  $V_{DD} = 2.5V$ ,  $T_A = 25^\circ C$
- Power-Off High Impedance inputs and outputs
- Industrial operation at  $-40^\circ C$  to  $+85^\circ C$
- Packages available:
  - 48-pin 240 mil. wide plastic TSSOP (A)
  - 48-pin 300 mil. wide plastic SSOP (V)

**Product Description**

Pericom Semiconductor's PI74VCX series of logic circuits are produced in the Company's advanced 0.35 micron CMOS technology, achieving industry leading speed.

The PI74VCX16245 is a 16-bit bidirectional transceiver designed for asynchronous two-way communication between data buses. The direction control input pin (xDIR) determines the direction of data flow through the bidirectional transceiver. The Direction and Output Enable controls are designed to operate this device as either two independent 8-bit transceivers or one 16-bit transceiver. The output enable ( $\overline{OE}$ ) input, when HIGH, disables both A and B ports by placing them in HIGH Z condition.

To ensure the high-impedance state during power up or power down,  $\overline{OE}$  should be tied to  $V_{cc}$  through a pull-up resistor; the minimum value of the resistor is determined by the current sinking ability of the driver.

The PI74VCX family is I/O Tolerant, allowing it to operate in mixed 1.8V/3.6V systems.

**Logic Block Diagram**

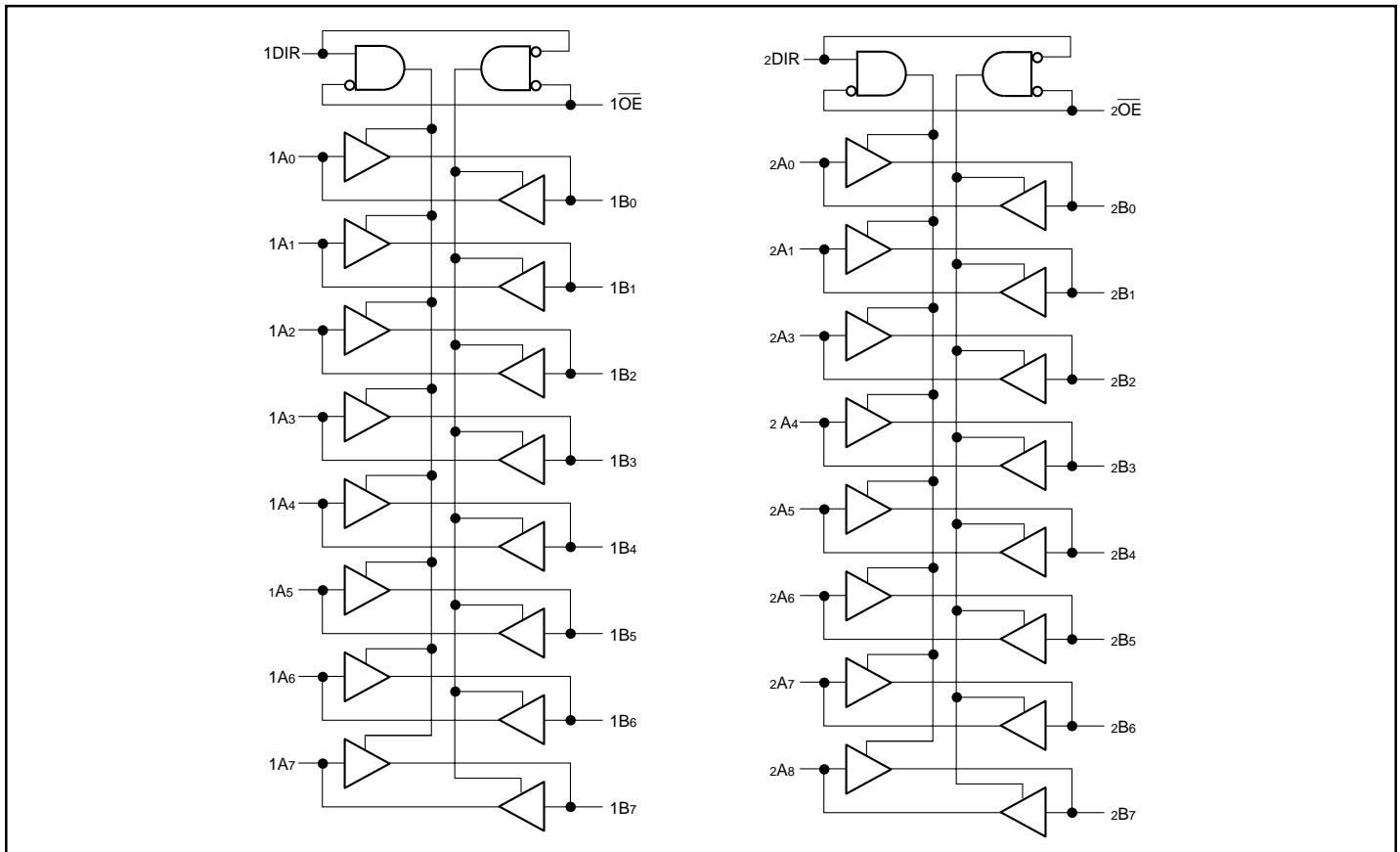

**Product Pin Description**

Pin Name	Description
$\overline{xOE}$	3-STATE Output Enable Inputs (Active LOW)
xDIR	Direction Control Input
xAx	Side A Inputs or 3-STATE Inputs
xBx	Side B Inputs or 3-STATE Outputs
GND	Ground
VCC	Power

**Truth Table<sup>(1)</sup>**

Inputs <sup>(1)</sup>		Outputs <sup>(1)</sup>
$\overline{xOE}$	xDIR	
L	L	Bus B Data to Bus A
L	H	Bus A Data to Bus B
H	X	High Z State

**Notes:**

- H = High Signal Level  
 L = Low Signal Level  
 X = Don't Care or Irrelevant  
 Z = High Impedance

**Product Pin Configuration**

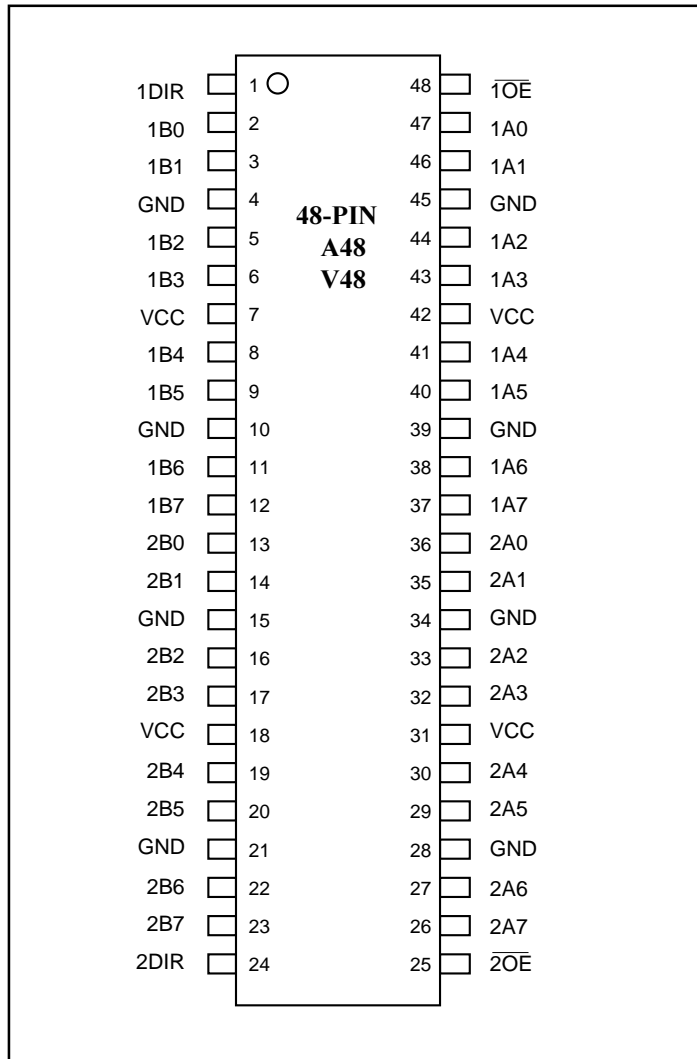

**Maximum Ratings**

(Above which the useful life may be impaired. For user guidelines, not tested.)

Supply Voltage Range, $V_{DD}$ .....	-0.5V to 4.6V
Input Voltage Range, $V_I$ .....	-0.5V to 4.6V
Output Voltage Range, $V_O$ (3-States) .....	-0.5V to 4.6V
Output Voltage Range, $V_O^{(1)}$ (Active).....	-0.5V to $V_{DD} + 0.5V$
DC Input Diode Current ( $I_{IK}$ ) $V_I < 0V$ .....	-50mA
DC Output Diode Current ( $I_{OK}$ )	
$V_O < 0V$ .....	-50mA
$V_O > V_{DD}$ .....	-50mA
DC Output Source/Sink Current ( $I_{OH}/I_{OL}$ ) .....	$\pm 50mA$
DC $V_{DD}$ or GND Current per Supply Pin ( $I_{CC}$ or GND) ....	$\pm 100mA$
Storage Temperature Range, $T_{STG}$ .....	-65°C to 150°C

**Note:**  
 Stresses greater than those listed under MAXIMUM RATINGS may cause permanent damage to the device. This is a stress rating only and functional operation of the device at these or any other conditions above those indicated in the operational sections of this specification is not implied. Exposure to absolute maximum rating conditions for extended periods may affect reliability.

**Recommended Operating Conditions<sup>(2)</sup>**

Parameters	Description	Min.	Max.	Units	
$V_{DD}$	Supply voltage	Operating	1.8	3.6	V
		Data Retention Only	1.2	3.6	
$V_I$	Input voltage	-0.3	3.6		
$V_O$	Output voltage	Active State	0	$V_{DD}$	
		Off State	0	3.6	
	Output current in $I_{OH}/I_{OL}$			mA	
			$V_{DD} = 3.0V$ to $3.6V$	$\pm 24$	
			$V_{DD} = 2.3V$ to $2.7V$	$\pm 18$	
			$V_{DD} = 1.8V$	$\pm 6$	
$\Delta t/\Delta v$	Input transition rise or fall rate <sup>(3)</sup>	0	10	ns/V	
$T_A$	Operating free-air temperature	-40	85	°C	

**Notes:**

1. Absolute maximum of  $I_O$  must be observed
2. Unused control inputs must be held HIGH or LOW to prevent them from floating
3. As measured between 0.8V and 2.0V,  $V_{DD} = 3.0V$

**Electrical Characteristics over Recommended Operating Free-Air Temperature Range**  
(unless otherwise noted)

**DC Characteristics (2.7V < V<sub>DD</sub> ≤ 3.6V)**

Parameters	Description	Conditions	V <sub>DD</sub>	Min.	Typ.	Max.	Units
V <sub>IH</sub>	HIGH Level Input Voltage			2.0			V
V <sub>IL</sub>	LOW Level Input Voltage		2.7 - 3.6			0.8	
V <sub>OH</sub>	HIGH Level Output Voltage	I <sub>OH</sub> = -100μA		V <sub>DD</sub> - 0.2			
		I <sub>OH</sub> = -12mA	2.7	2.2			
		I <sub>OH</sub> = -18mA	3.0	2.4			
		I <sub>OH</sub> = -24mA		2.2			
V <sub>OL</sub>	LOW Level Output Voltage	I <sub>OL</sub> = 100μA	2.7 - 3.6			0.2	
		I <sub>OL</sub> = 12mA	2.7			0.4	
		I <sub>OL</sub> = 18mA	3.0			0.4	
		I <sub>OL</sub> = 24mA				0.55	
I <sub>I</sub>	Input Leakage Current	0V ≤ V <sub>I</sub> ≤ 3.6V	2.7 - 3.6			±5.0	μA
I <sub>OZ</sub>	3-STATE Output Leakage	0 ≤ V <sub>O</sub> ≤ 3.6V V <sub>I</sub> = V <sub>IH</sub> or V <sub>IL</sub>	2.7 - 3.6			±10	
I <sub>OFF</sub>	Power-OFF Leakage Current	0 ≤ (V <sub>I</sub> , V <sub>O</sub> ) ≤ 3.6V	0			10	
I <sub>DD</sub>	Quiescent Supply Current	V <sub>I</sub> = V <sub>DD</sub> to GND	2.7 - 3.6			20	
		V <sub>DD</sub> ≤ (V <sub>I</sub> , V <sub>O</sub> ) ≤ 3.6V				±20	
ΔI <sub>DD</sub>	Increase in I <sub>DD</sub> per input	V <sub>IH</sub> = V <sub>DD</sub> - 0.6V, Other inputs at V <sub>DD</sub> or GND					750

**DC Characteristics ( $2.3V \leq V_{DD} \leq 2.7V$ )**

Parameters	Description	Conditions	$V_{DD}$	Min.	Typ.	Max.	Units
$V_{IH}$	HIGH Level Input Voltage		2.3 - 2.7	1.6			V
$V_{IL}$	LOW Level Input Voltage					0.7	
$V_{OH}$	HIGH Level Output Voltage	$I_{OH} = -100\mu A$		$V_{DD} - 0.2$			
		$I_{OH} = -6mA$	2.3	2.0			
		$I_{OH} = -12mA$		1.8			
		$I_{OH} = -18mA$		1.7			
$V_{OL}$	LOW Level Output Voltage	$I_{OL} = 100\mu A$	2.3 - 2.7			0.2	
		$I_{OL} = 12mA$	2.3			0.4	
		$I_{OL} = 18mA$				0.6	
$I_I$	Input Leakage Current	$0V \leq V_I \leq 3.6V$	2.3 - 2.7			$\pm 5.0$	
$I_{OZ}$	3-STATE Output Leakage	$0 \leq V_O \leq 3.6V$ $V_I = V_{IH}$ or $V_{IL}$	2.3 - 2.7			$\pm 10$	
$I_{OFF}$	Power-OFF Leakage Current	$0 \leq (V_I, V_O) \leq 3.6V$	0			10	
$I_{DD}$	Quiescent Supply Current	$V_I = V_{DD}$ or GND	2.3 - 2.7			20	
		$V_{DD} \leq (V_I, V_O) \leq 3.6V$				$\pm 20$	

**Electrical Characteristics over Recommended Operating Free-Air Temperature Range**
**DC Characteristics ( $1.8V \leq V_{DD} \leq 2.3V$ )**

Parameters	Description	Conditions	$V_{DD}$	Min.	Typ.	Max.	Units	
$V_{IH}$	HIGH Level Input Voltage		1.8 - 2.3	$0.7 \times V_{DD}$			V	
$V_{IL}$	LOW Level Input Voltage					$0.2 \times V_{DD}$		
$V_{OH}$	HIGH Level Output Voltage	$I_{OH} = -100mA$		$V_{DD} - 0.2$				
		$I_{OH} = -6mA$		1.4				
$V_{OL}$	LOW Level Output Voltage	$I_{OL} = 100mA$	1.8			0.2		
		$I_{OH} = -6mA$				0.3		
$I_I$	Input Leakage Current	$0V \leq V_I \leq 3.6V$				$\pm 5.0$		
$I_{OZ}$	3-State Output Leakage	$0V \leq V_O \leq 3.6V$ $V_I = V_{IH}$ or $V_{IL}$				$\pm 10$		
$I_{OFF}$	Power-OFF Leakage Current	$0V \leq (V_I, V_O) \leq 3.6V$	0			10		mA
$I_{DD}$	Quiescent Supply Current	$V_I = V_{DD}$ or GND	1.8			20		
		$V_{DD} \leq (V_I, V_O) \leq 3.6V$	1.8			$\pm 20$		

### AC Electrical Characteristics

Symbol	Parameters	$T_A = -40^{\circ}\text{C to } +85^{\circ}\text{C}, C_L = 30\text{pF}, R_L = 500\Omega$						Units
		$V_{DD} = 3.3\text{V} \pm 0.3\text{V}$		$V_{DD} = 2.5\text{V} \pm 0.2\text{V}$		$V_{DD} = 1.8\text{V}$		
		Min.	Max.	Min.	Max.	Min.	Max.	
$t_{PHL}, t_{PLH}$	Prop Delay	0.8	2.5	1.0	3.2	1.5	5.7	ns
$t_{PZL}, t_{PZH}$	Output Enable Time	0.8	3.8	1.0	4.9	1.5	7.5	
$t_{PLZ}, t_{PHZ}$	Output Disable Time	0.8	3.7	1.0	4.2	1.5	5.5	
$t_{OSHL}$ $t_{OSLH}$	Output to Output Skew <sup>(2)</sup>		0.5		0.5		0.5	

**Notes:**

1. For  $C_L = 50\text{pF}$ , add approximately 300ps to the maximum AC specification
2. Skew is defined as the absolute value of the difference between the actual propagation delay for any two separate outputs of the same device. The specification applies to any outputs switching in the same direction, either HIGH or LOW ( $t_{OSHL}$ ) or LOW to HIGH ( $t_{OSLH}$ ).

### Dynamic Switching Characteristics

Symbol	Parameters	Conditions	$V_{DD}$	$T_A = +25^{\circ}\text{C}$ Typical	Units
$V_{OLP}$	Quiet Output Dynamic Peak $V_{OL}$	$C_L = 30\text{pF}$ $V_{IH} = V_{DD}$ $V_{IL} = 0\text{V}$	1.8	0.25	V
			2.5	0.6	
			3.3	0.8	
$V_{OLV}$	Quiet Output Dynamic Valley $V_{OL}$	$C_L = 30\text{pF}$ $V_{IH} = V_{DD}$ $V_{IL} = 0\text{V}$	1.8	-0.25	
			2.5	-0.6	
			3.3	-0.8	
$V_{OHV}$	Quiet Output Dynamic Valley $V_{OH}$	$C_L = 30\text{pF}$ $V_{IH} = V_{DD}$ $V_{IL} = 0\text{V}$	1.8	1.5	
			2.5	1.9	
			3.3	2.2	

### Capacitance

Symbols	Parameters	Conditions	$T_A = +25^{\circ}\text{C}$ Typical	Units
$C_{IN}$	Input Capacitance	$V_{DD} = 1.8, 2.5\text{V or } 3.3\text{V}, V_I = 0\text{V or } V_{DD}$	6	pF
$C_{OUT}$	Output Capacitance	$V_I = 0\text{V or } V_{DD}, V_{DD} = 1.8\text{V}, 2.5\text{V or } 3.3\text{V}$	7	
$C_{PD}$	Power Dissipation Capacitance	$V_I = 0\text{V or } V_{DD}, F = 10\text{ MHz}$ $V_{DD} = 1.8\text{V}, 2.5\text{V or } 3.3\text{V}$	20	

### Test Circuits and Switching Waveforms

#### Parameter Measurement Information ( $V_{DD} = 1.8V - 3.6V$ )

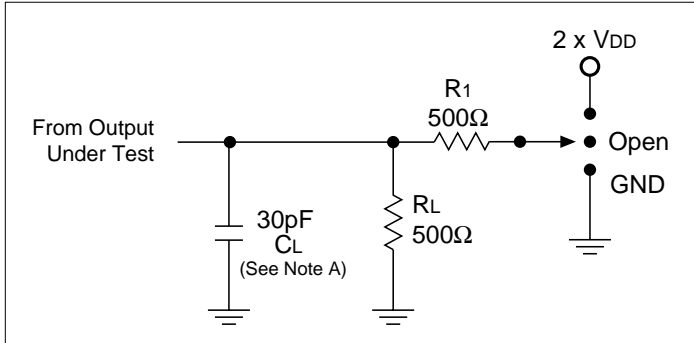

#### Switch Position

Test	S1
$t_{PD}$	Open
$t_{PLZ}/t_{PZL}$	$2 \times V_{DD}$
$t_{PHZ}/t_{PZH}$	GND

#### Setup, Hold, and Release Timing

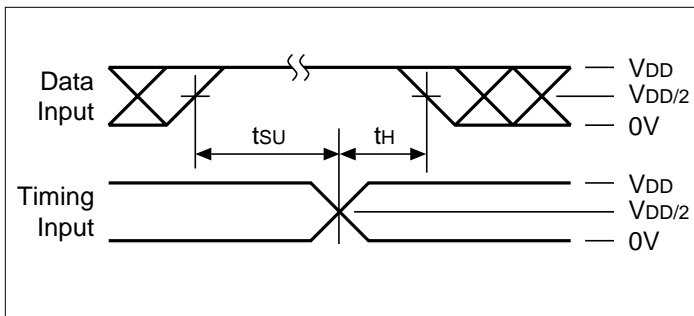

#### Notes:

- A.  $C_L$  includes probe and jig capacitance.
- B. Waveform 1 is for an output with internal conditions such that the output is LOW except when disabled by the output control. Waveform 2 is for an output with internal conditions such that the output is HIGH except when disabled by the output control.
- C. All input pulses are supplied by generators having the following characteristics:  
 $PRR \leq 10 \text{ MHz}$ ,  $Z_O = 50\Omega$ ,  
 $t_R \leq 2\text{ns}$ ,  
 $t_F \leq 2\text{ns}$ ,  
*measured from 10% to 90%, unless otherwise specified.*
- D. The outputs are measured one at a time with one transition per measurement.

#### Pulse Width

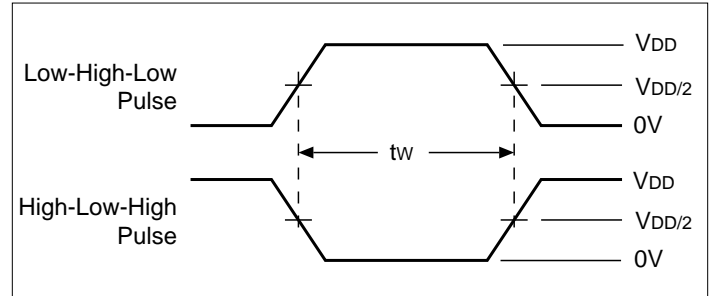

#### Propagation Delay

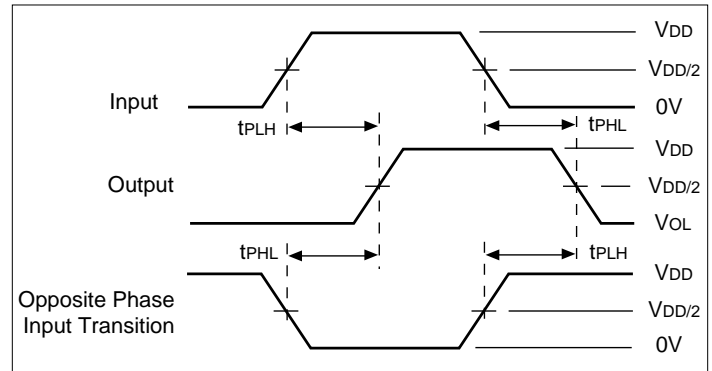

#### Enable Disable Timing

