

## Differential Positive ECL (DPECL) Fast Edge PJ-A2960 Series

Rev. -

### PRELIMINARY

#### Description

The **PJ-A2960 Series** of quartz crystal oscillators provide DPECL Fast Edge compatible signals. Systems designers may now specify space-saving, cost-effective packaged PECL oscillators to meet their timing requirements.

#### Features

- Wide frequency range—125.0MHz to 312.5MHz
- User specified tolerance available
- Will withstand vapor phase temperatures of 253°C for 4 minutes maximum
- Space-saving alternative to discrete component oscillators
- High shock resistance, to 1000g
- 3.3 volt operation
- Metal lid electrically connected to ground to reduce EMI
- Fast rise and fall times <600 ps
- High Reliability - NEL HALT/HASS qualified for crystal oscillator start-up conditions
- Low Jitter - Wavecrest jitter characterization available
- Overtone technology
- High Q Crystal actively tuned oscillator circuit
- Power supply decoupling internal
- No internal PLL avoids cascading PLL problems
- High frequencies due to proprietary design
- Gold plated pads

#### Electrical Connection

Pin Connection

1	Enable/Disable
2	N.C.
3	V <sub>EE</sub> /Ground
4	Output
5	/Output
6	V <sub>CC</sub>

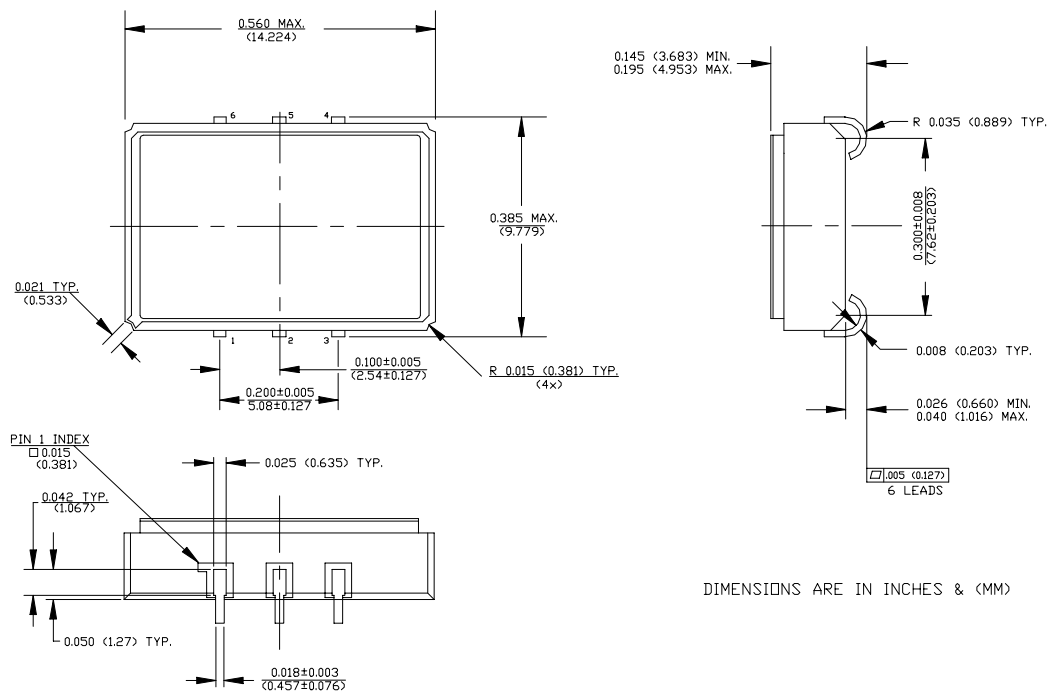

**PJ-A2960 Series** Continued  
Differential Positive ECL (DPECL) Fast Edge

Rev. -

## Operating Conditions and Output Characteristics

### Electrical Characteristics

Parameter	Symbol	Conditions	Min	Typical	Max
Frequency	-----	-----	125.0MHz	-----	312.5MHz
Duty Cycle	-----	@ V <sub>CC</sub> -1.29V	45/55%	-----	55/45%
Logic 0 <sup>(2)</sup>	V <sub>OL</sub>	-----	1.35V	-----	1.70V
Logic 1 <sup>(2)</sup>	V <sub>OH</sub>	-----	2.28V	-----	2.56V
Rise & Fall Time	tr,tf	20-80%V <sub>O</sub> with 50 ohm load to V <sub>CC</sub> -2V	-----	-----	600 psec
T <sub>pd</sub> <sup>(4)</sup>	-----	-----	-200 psec	-----	+200 psec
Jitter, RMS <sup>(3)</sup>	-----	-----	-----	-----	3 psec
Enable Voltage <sup>(5)</sup>	-----	with V <sub>EE</sub> = 0V	0V	-----	1.0V
Disable Voltage	-----	with V <sub>EE</sub> = 0V	3.0V	-----	V <sub>CC</sub>
Frequency Stability <sup>(1)</sup>	dF/F	Overall conditions including: voltage, calibration, temp., 10 yr aging, shock, vibration	-100ppm	-----	+100ppm

### General Characteristics

Parameter	Symbol	Conditions	Min	Typical	Max
Supply Voltage	V <sub>CC</sub>	-----	3.15V	3.3V	3.45V
Supply Current	I <sub>CC</sub>	50 ohm termination To 2.00V below V <sub>CC</sub>	0.0 mA	-----	80 mA
Output current	I <sub>O</sub>	Low level Output Current	0.0 mA	-----	±50.0 mA
Operating temperature	T <sub>A</sub>	-----	0°C	-----	70°C
Storage temperature	T <sub>S</sub>	-----	-55°C	-----	125°C
Power Dissipation	P <sub>D</sub>	-----	-----	-----	276 mW
Lead temperature	T <sub>L</sub>	Soldering, 10 sec.	-----	-----	300°C
Load	-----	50 Ohm to V <sub>CC</sub> -2V or Thevenin Equivalent, Bias Required	-----	-----	-----
Start-up time	t <sub>S</sub>	-----	-----	2 ms	10 ms

### Environmental and Mechanical Characteristics

Mechanical Shock	Per MIL-STD-202, Method 213, Condition E
Thermal Shock	Per MIL-STD-833, Method 1011, Condition A
Vibration	0.060" double amplitude 10 Hz to 55 Hz, 35g's 55Hz to 2000 Hz
Soldering Condition	300°C for 10 seconds
Hermetic Seal	Leak rate less than 1 x 10 <sup>-8</sup> atm.cc/sec of helium

#### Footnotes:

- 1) Standard frequency stability (±20,±25,±50ppm & others available)
- 2) V<sub>OL</sub>, V<sub>OH</sub>, referenced to ground (V<sub>EE</sub>) with V<sub>CC</sub> = 3.3V
- 3) Jitter performance is frequency dependent. Please contact factory for full Wavecrest characterization.
- 4) T<sub>pd</sub> is phse shift between the falling edge of pin 4 at 2.0V and the rising edge of pin 5 at 2.01V.
- 5) Open to enable pin also enables the output.

