

LF100SI Series

High Isolation, 1W Single Output SMT DC/DC Converters

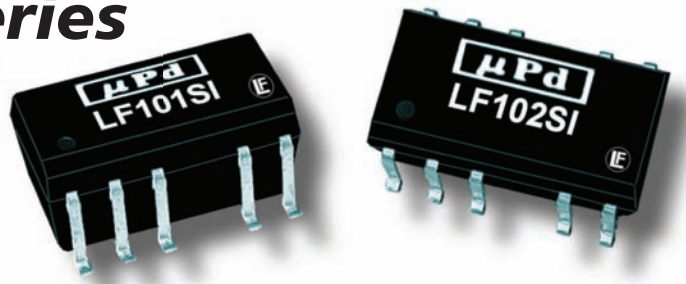

Key Features:

- 1W Output Power
- Ultra-Miniature SMT Case
- 3,000 VDC Isolation
- 5V, 12V & 24V Inputs
- -40°C to +85°C Operation
- 9 Standard Models
- 2.0 MH MTBF Minimum
- Industry Standard Pin-Out



RoHS Compliant

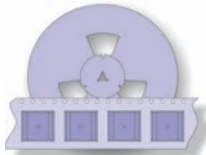

Tape/Reel Available

MicroPower Direct

292 Page Street
Suite D
Stoughton, MA 02072
USA

T: (781) 344-8226
F: (781) 344-8481
E: sales@micropowerelectronics.com
W: www.micropowerelectronics.com



Electrical Specifications

Specifications typical @ +25°C, nominal input voltage & rated output current, unless otherwise noted. Specifications subject to change without notice.

Input

Parameter	Conditions	Min.	Typ.	Max.	Units
Input Voltage Range	5 VDC Input	4.5	5.0	5.5	VDC
	12 VDC Input	10.8	12.0	13.2	
	24 VDC Input	21.6	24.0	26.4	
Reverse Polarity Input Current				0.3	A
Input Filter	Capacitor				

Output

Parameter	Conditions	Min.	Typ.	Max.	Units
Output Voltage Accuracy			±1.5	±4.0	%
Line Regulation	For Vin Change of 1%		±1.2	±1.5	%
Load Regulation (Note 1)	See Model Selection Guide				
Ripple & Noise (20 MHz) (Note 2)			75	100	mV P - P
Ripple & Noise (20 MHz)	Over Line, Load & Temp.			150	mV P - P
Ripple & Noise (20 MHz)				5	mv rms
Output Power Protection		120			%
Temperature Coefficient			±0.01	±0.02	%/°C
Output Short Circuit	Momentary (0.5 Sec.)				

General

Parameter	Conditions	Min.	Typ.	Max.	Units
Isolation Voltage	60 Seconds	3,000			VDC
Isolation Resistance	500 VDC	10			GΩ
Isolation Capacitance	100 kHz, 1V		60	100	pF
Switching Frequency		50	100	150	kHz

Environmental

Parameter	Conditions	Min.	Typ.	Max.	Units
Operating Temperature Range	Ambient	-40	+25	+85	°C
Operating Temperature Range	Case	-40		+90	°C
Storage Temperature Range		-40		+125	°C
Cooling	Free Air Convection				
Humidity	RH, Non-condensing			95	%

Physical

Case Size	0.60 x 0.31 x 0.26 Inches (15.24 x 8.0 x 6.7 mm)				
Case Material	Molded Black Plastic (UL94-V0)				
Weight	0.07 Oz (2.2g)				

Reliability Specifications

Parameter	Conditions	Min.	Typ.	Max.	Units
MTBF	MIL HDBK 217F, 25°C, Gnd Benign	2.0			MHours

Absolute Maximum Ratings

Parameter	Conditions	Min.	Typ.	Max.	Units
Input Voltage Surge (1 Sec)	5 VDC Input	-0.7		9.0	VDC
	12 VDC Input	-0.7		18.0	
	24 VDC Input	-0.7		30.0	
Lead Temperature	1.5 mm From Case For 10 Sec.			300	°C
Internal Power Dissipation	All Models			550	mW

Caution: Exceeding Absolute Maximum Ratings may damage the module. These are not continuous operating ratings.

Model Selection Guide

Model Number	Input				Output			Load Regulation (% Max)	Efficiency (% Typ)	Fuse Rating Slow-Blow (mA)
	Voltage (VDC)		Current (mA)		Voltage (VDC)	Current (mA, Max)	Current (mA, Min)			
	Nominal	Range	Full-Load	No-Load						
LF101SI	5	4.5 - 5.5	281	30	5.0	200.0	4.0	10	71	500
LF102SI	5	4.5 - 5.5	258	30	12.0	84.0	1.5	7	78	500
LF103SI	5	4.5 - 5.5	258	30	15.0	67.0	1.0	7	78	500
LF111SI	12	10.8 - 13.2	117	12	5.0	200.0	4.0	8	71	200
LF112SI	12	10.8 - 13.2	106	12	12.0	84.0	1.5	5	79	200
LF113SI	12	10.8 - 13.2	104	12	15.0	67.0	1.0	5	80	200
LF121SI	24	21.6 - 26.4	58	7	5.0	200.0	4.0	8	71	100
LF122SI	24	21.6 - 26.4	53	7	12.0	84.0	1.5	5	78	100
LF123SI	24	21.6 - 26.4	53	7	15.0	67.0	1.0	5	79	100

Notes:

- Load regulation is measured for an output change of 20% to 100%.
- When measuring output ripple, it is recommended that an external 0.33 μF ceramic capacitor be placed from the +Vout pin to the -Vout pin. For noise sensitive applications, the use of 0.47 μF capacitors will reduce the output ripple.
- Operation at no-load will not damage these units. However, they may not meet all specifications.
- The converter should be connected to a low ac-impedance source. An input source with a highly inductive impedance may affect the stability of the converter. In applications where the converter output loading is high and input power is supplied over long lines, it may be necessary to use a capacitor on the input to insure start-up. In this case, it is recommended that a low ESR ($\text{ESR} < 1.0\Omega$ at 100 kHz) capacitor be mounted close to the converter. For 5V input units a 2.2 μF is recommended, for 12V input units, a 1.0 μF , and for 24V input units, a 0.47 μF .
- It is recommended that a fuse be used on the input of a power supply for protection. See the table above for the correct rating.

Derating Curve

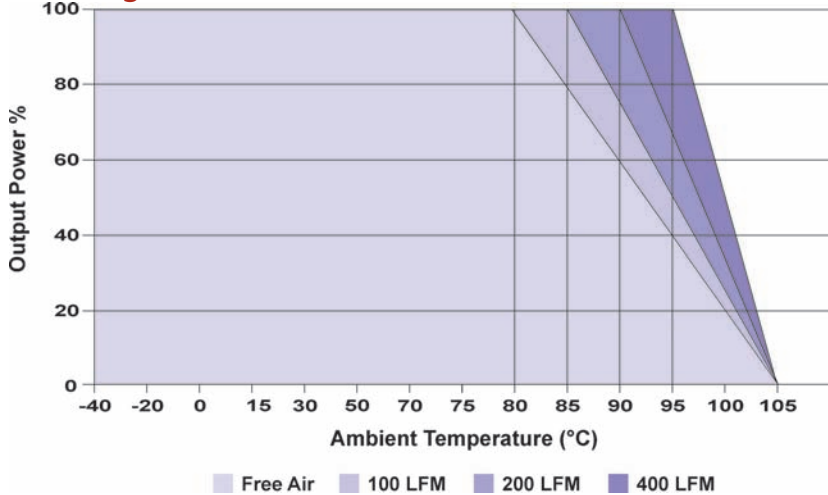

Mechanical Dimensions

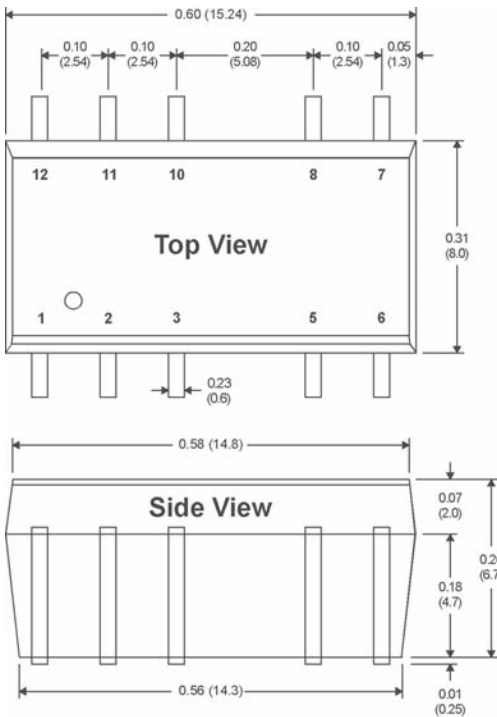

Pin Connections

Pin	Description	Pin	Description
1	-Vin	7	NA
2	+Vin	8	+Vout
3	NA	10	NA
5	-Vout	11	NA
6	NA	12	NA

NA = Not available for connection

Board Layout

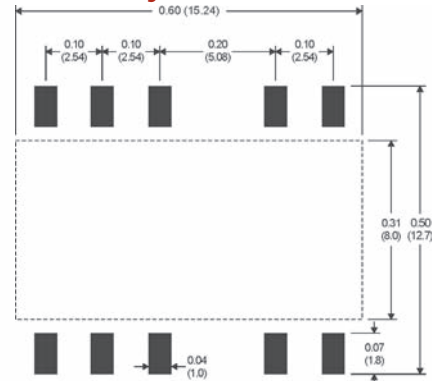

Capacitive Load

5V Out μF Max	12 & 15V Out μF Max
33	4.7

Notes:

- All dimensions are typical in inches (mm)
- Tolerance: Inches x.xx = ± 0.01
Millimeters x.x = ± 0.25
x.xx = ± 0.13
Pin: ± 0.002 (± 0.05)
- Pin 1 is marked by a "dot" or indentation on the unit. The curved edge of the case indicates the Pin 1 side.



MicroPower Direct
www.micropowerdirect.com