

ILA1062A

Low Voltage Transmission Circuit with Dialler Interface

The ILA1062A is an integrated circuit that perform all speech and line interface functions required in fully electronic telephone sets. They perform electronic switching between dialling and speech. The ICs operate at line voltage down to 1.6 V DC (with reduced performance) to facilitate the use of more telephone sets connected in parallel.

- Low DC line voltage: operates down to 1.6 V (excluding polarity guard)
- Voltage regulator with adjustable static resistance
- Provides a supply for external circuits
- Symmetrical high-impedance inputs (64 K Ω) for dynamic, magnetic or piezo-electric microphones
- Asymmetrical high-impedance input (32 K Ω) for electret microphones
- DTMF signal input with confidence tone
- Mute input for pulse or DTMF dialing: active LOW (MUTE)
- Receiving amplifier for dynamic, magnetic or piezo-electric earpieces
- Large gain setting ranges on microphone and earpiece amplifiers
- Line loss compensation (line current dependent) for microphone and earpiece amplifiers
- Gain control curve adaptable to exchange supply
- DC line voltage adjustment facility

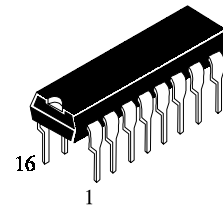

N SUFFIX
PLASTIC

ORDERING INFORMATION

ILA1062AN Plastic
T_A = -25° to 75° C
for package

PIN ASSIGNMENT

LN	1 ●	16	SLPE
GAS1	2	15	AGC
GAS2	3	14	REG
QR	4	13	V _{CC}
GAR	5	12	MUTE
MIC-	6	11	DTMF
MIC+	7	10	IR
STAB	8	9	V _{EE}

BLOCK DIAGRAM

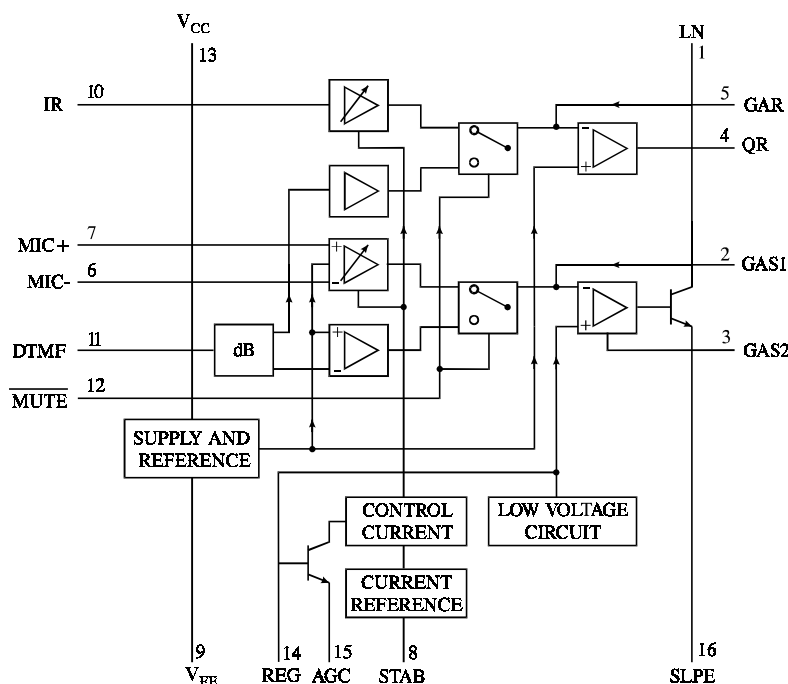

PIN DESCRIPTION

Pin No	Designation	Description
1	LN	positive line terminal
2	GAS1	gain adjustment; transmitting amplifier
3	GAS2	gain adjustment; transmitting amplifier
4	QR	non-inverting output; receiving amplifier
5	GAR	gain adjustment; receiving amplifier
6	MIC-	inverting microphone input
7	MIC+	non-inverting microphone input
8	STAB	current stabilizer
9	V _{EE}	negative line terminal
10	IR	receiving amplifier input
11	DTMF	dual-tone multi-frequency input
12	MUTE	mute input
13	V _{CC}	positive supply decoupling
14	REG	voltage regulator decoupling
15	AGC	automatic gain control input
16	SLPE	slope (DC resistance) adjustment

FUNCTIONAL DESCRIPTION

Supplies V_{CC}, LN, SLPE, REG and STAB

Power for the IC and its peripheral circuits is usually obtained from the telephone line. The supply voltage is derived from the line via a dropping resistor and regulated by the IC. The supply voltage V_{CC} may also be used to supply external circuits e.g. dialling and control circuits.

Decoupling of the supply voltage is performed by a capacitor between V_{CC} and V_{EE}. The internal voltage regulator is decoupled by a capacitor between REG and V_{EE}.

The DC current flowing into the set is determined by the exchange supply voltage V_{exch}, the feeding bridge resistance R_{exch} and the DC resistance of the telephone line R_{line}.

The circuit has an internal current stabilizer operating at a level determined by a 3.6 KΩ resistor connected between STAB and V_{EE} (see Fig.1).

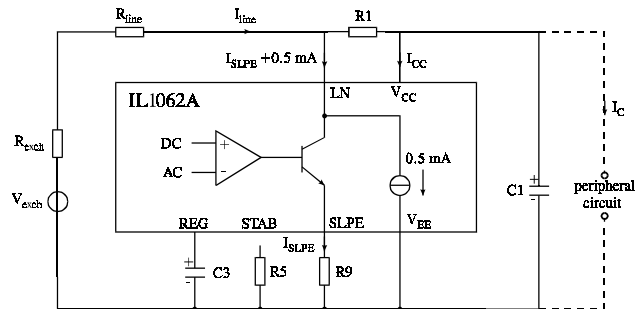

Figure 1. Supply arrangement

When the line current (I_{line}) is more than 0.5 mA greater than the sum of the IC supply current (I_{CC}) and the current draw by the peripheral circuitry connected to V_{CC} (I_p) the excess current is shunted to V_{EE} via LN.

The regulated voltage on the line terminal (V_{LN}) can be calculated as:

$$V_{LN} = V_{ref} + I_{SLPE} \times R9$$

$$V_{LN} = V_{ref} + ((I_{line} - I_{CC} - 0.5 \times 10^{-3} \text{ A}) - I_p) \times R9$$

V_{ref} is an internally generated temperature compensated reference voltage of 3.7 V and R9 is an external resistor connected between SLPE and V_{EE} .

In normal use the value of R9 would be 20Ω.

Changing the value of R9 will also affect microphone gain, DTMF gain, gain control characteristics, sidetone level, maximum output swing on LN and the DC characteristics (especially at the lower voltages).

Under normal conditions, when $I_{SLPE} \gg I_{CC} + 0.5 \text{ mA} + I_p$, the static behaviour of the circuit is that of a 3.7 V regulator diode with an internal resistance equal to that of R9. In the audio frequency range the dynamic impedance is largely determined by R1. Fig.2 shows the equivalent impedance of the circuit.

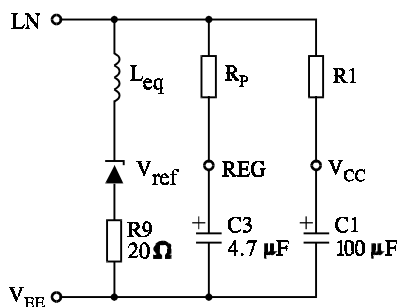

$$L_{eq} = C3 \times R9 \times R_p$$

$$R_p = 16.2 \text{ K}\Omega$$

Figure 2. Equivalent impedance circuit

At line currents below 9 mA the internal reference voltage is automatically adjusted to a lower value (typically 1.6 V at 1 mA) This means that more sets can be operated in parallel with DC line voltages (excluding the polarity guard) down to an absolute minimum voltage of 1.6 V.

At line currents below 9 mA the circuit has limited sending and receiving levels. The internal reference voltage can be adjusted by means of an external resistor (R_{VA}). This resistor when connected between LN and REG will decrease the internal reference voltage and when connected between REG and SLPE will increase the internal reference voltage.

Microphone inputs MIC+ and MIC- and gain pins GAS1 and GAS2

The circuit has symmetrical microphone inputs. Its input impedance is 64 KΩ (2 x 32 KΩ) and its voltage gain is typically 52 dB (when $R7 = 68 \text{ K}\Omega$, see Figure 3). Dynamic, magnetic, piezo-electric or electret (with built-in FET source followers) can be used.

The gain of the microphone amplifier can be adjusted between 44 dB and 52 dB to suit the sensitivity of the transducer in use. The gain is proportional to the value of R7 which is connected between GAS1 and GAS2.

Stability is ensured by two external capacitors, C6 connected between GAS1 and SLPE and C8 connected between GAS1 and V_{EE} . The value of C6 is 100 pF but this may be increased to obtain a first-order low-pass filter. The value of C8 is 10 times the value of C6. The cut-off frequency corresponds to the time constant $R7 \times C6$.

Input MUTE

When MUTE is LOW or open circuit, the DTMF input is enabled and the microphone and receiving amplifier inputs are inhibited. The reverse is true when MUTE is HIGH, MUTE switching causes only negligible clicking on the line and earpiece output. If the number of parallel sets in use causes a drop in line current to below 6 mA the DTMF amplifier becomes active independent to the DC level applied to the MUTE input.

Dial-tone multi-frequency input DTMF

When the DTMF input is enabled dialling tones may be sent on to the line. The voltage gain from DTMF to LN is typically 25.5 dB (when $R7 = 68 \text{ K}\Omega$) and varies with R7 in the same way as the microphone gain. The signalling tones can be heard in the earpiece at a low level (confidence tone).

Receiving amplifier IR, QR and GAR

The receiving amplifier has one input (IR) and a non-inverting output (QR). The IR to QR gain is typically 31 dB (when $R4 = 100 \text{ K}\Omega$). It can be adjusted between 20 and 31 dB to match the sensitivity of the transducer in use. The gain is set with the value of R4 which is connected between GAR and QR. The overall receive gain, between LN and QR, is calculated by subtracting the anti-sidetone network attenuation (32 dB) from the amplifier gain. Two external capacitors, C4 and C7, ensure stability. C4 is normally 100 pF and C7 is 10 times the value of C4. The value of C4 may be increased to obtain a first-order low-pass filter. The cut-off frequency will depend on the time constant $R4 \times C4$.

The output voltage of the receiving amplifier is specified for continuous-wave drive. The maximum output voltage will be higher under speech conditions where the peak to RMS ratio is higher.

Automatic gain control input AGC

Automatic line loss compensation is achieved by connecting a resistor (R6) between AGC and V_{EE}.

The automatic gain control varies the gain of the microphone amplifier and the receiving amplifier in accordance with the DC line current. The control range is 5.8 dB which corresponds to a line length of 5 km for a 0.5 mm diameter twisted-pair copper cable with a DC resistance of 176 Ω/km and average attenuation of 1.2 dB/km. Resistor R6 should be chosen in accordance with the exchange supply voltage and its feeding bridge resistance (see Table 1).

Table 1 Values of resistor R6 for optimum line-loss compensation at various values of exchange supply voltage (V_{exch}) and exchange feeding bridge resistance (R_{exch}); R9 = 20 Ω.

V _{exch} (V)	400	600	800	1000
	R _{exch} (Ω)	R _{exch} (Ω)	R _{exch} (Ω)	R _{exch} (Ω)
	R6(KΩ)			
36	100	78.7	-	-
48	140	110	93.1	82
60	-	-	120	102

The ratio of start and stop currents of the AGS curve is independent of the value of R6. If no automatic line-loss compensation is required the AGS pin may be left open-circuit. The amplifiers, in this condition, will give their maximum specified gain.

Sidetone suppression

The anti-sidetone network, R1//Z_{line}, R2, R3, R8,

MAXIMUM RATINGS*

Symbol	Parameter	Condition	Min	Max	Unit
V _{LN}	Positive continuous line voltage		-	12	V
V _{LN(R)}	Repetitive line voltage during switch-on or line interruption		-	13.2	V
V _{LN(RM)}	Repetitive peak line voltage for a 1 ms pulse per 5 s	R9 = 20 Ω; R10 = 13 Ω; see Fig.5	-	28	V
I _{line}	Line current	R9 = 20 Ω	-	140	mA
V _{IN}	Input voltage on all other pins	positive input voltage	-	V _{CC} +0.7	V
		negative input voltage	-	-0.7	V
P _D	Total power dissipation	R9 = 20 Ω; note 1	-	666	mW
T _{stg}	Storage temperature		-40	+125	°C

* Maximum Ratings are those values beyond which damage to the device may occur. Functional operation should be restricted to the Recommended Operating Conditions.

Note 1. Calculated for the maximum operating temperature specified (T_{amb} = 75°C) and a maximum junction temperature of 125°C.

R9 and Z_{bal} (see Fig4) suppresses the transmitted signal in the earpiece. Maximum compensation is obtained when the following conditions are fulfilled:

$$R9 \times R2 = R1 \times \left(R3 + \frac{R8 \times Z_{bal}}{R8 + Z_{bal}} \right) \quad (1)$$

$$\frac{Z_{bal}}{Z_{bal} + R8} = \frac{Z_{line}}{Z_{line} + R1} \quad (2)$$

If fixed values are chosen for R1, R2, R3 and R9, then condition (1) will always be fulfilled when |R8/Z_{bal}| << R3.

To obtain optimum sidetone suppression, condition (2) has to be fulfilled which results in:

$$Z_{bal} = \frac{R8}{R1} Z_{line} = k \times Z_{line}$$

Where k is a scale factor; k = $\frac{R8}{R1}$

The scale factor k, dependent on the value of R8, is chosen to meet the following criteria:

- compatibility with a standard capacitor from the E6 or E12 range for Z_{bal}
- |Z_{bal}//R8| << R3 fulfilling condition (a) and thus ensuring correct anti-sidetone bridge operation
- |Z_{bal} + R8| >> R9 to avoid influencing the transmit gain.

In practise Z_{line} varies considerably with the line type and length. The value chosen for Z_{bal} should therefore be for an average line length thus giving optimum setting for short or long lines.

RECOMMENDED OPERATING CONDITIONS

Symbol	Parameter	Conditions	Min	Typ	Max	Unit
I _{line}	Operating line current normal operation with reduced performance		11	-	140	mA
			1	-	11	mA
V _{CC}	Supply voltage for peripherals	I _{line} = 15 mA	2.2	-	-	V
		I _p = 1.2 mA; MUTE = LOW I _p = 0 mA; MUTE = LOW	-	3.4	-	V
G _V	Voltage gain microphone amplifier receiving amplifier		44	-	52	dB
			20	-	31	dB
T _{amb}	Operating ambient temperature		-25	-	+75	°C
Line loss compensation						
ΔG _V	Gain control		-	5.8	-	dB
V _{exch}	Exchange supply voltage		36	-	60	V
R _{exch}	Exchange feeding bridge resistance		0.4	-	1	KΩ

This device contains protection circuitry to guard against damage due to high static voltages or electric fields. However, precautions must be taken to avoid applications of any voltage higher than maximum rated voltages to this high-impedance circuit. For proper operation, V_{IN} and V_{OUT} should be constrained to the range GND ≤ (V_{IN} or V_{OUT}) ≤ V_{CC}.

Unused inputs must always be tied to an appropriate logic voltage level (e.g., either GND or V_{CC}). Unused outputs must be left open.

ELECTRICAL CHARACTERISTICS (I_{line} = 11 to 140 mA; V_{EE} = 0 V; f = 800 Hz; T_{amb} = 25°C; unless other specified)

Symbol	Parameter	Test Conditions	Guaranteed Limits			Unit
			Min	Typ	Max	
Supplies LN and V_{CC} (pins 1 and 13)						
V _{LN}	Voltage Drop Over Circuit between LN and V _{EE}	MIC Inputs Open-Circuit				V
		I _{line} = 1 mA	-	1.6	-	
		I _{line} = 4 mA	-	1.9	-	
		I _{line} = 15 mA	3.56	-	4.25	
		I _{line} = 100 mA	4.9	-	6.5	
		I _{line} = 140 mA	-	-	7.5	
ΔV _{LN} /ΔT	Variation with Temperature	I _{line} = 15 mA	-	-0.3	-	mV/K
V _{LN}	Voltage Drop Over Circuit between LN and V _{EE} with External Resistor R _{VA}	I _{line} = 15 mA		3.5		V
		R _{VA} (LN to REG)=68KΩ R _{VA} (LN to SLPE)=39KΩ		4.5		
I _{CC}	Supply Current	V _{CC} = 2.8 V			1.35	mA

(continued)

ELECTRICAL CHARACTERISTICS ($I_{line} = 11$ to 140 mA; $V_{EE} = 0$ V; $f = 800$ Hz; $T_{amb} = 25^{\circ}\text{C}$; unless other specified)

Symbol	Parameter	Test Conditions	Guaranteed Limits			Unit
			Min	Typ	Max	
Microphone inputs MIC- and MIC+ (pins 6 and 7)						
$ Z_i $	Input Impedance differential single-ended	between MIC- and MIC+ MIC- or MIC+ to V_{EE}	- -	64 32	- -	K Ω
CMRR	Common Mode Rejection Ratio		-	82	-	dB
G_v	Voltage Gain MIC+ or MIC- to LN	$I_{line} = 15$ mA $R7 = 68$ K Ω	50.5		53.5	dB
ΔG_{vf}	Gain Variation with Frequency Reference to 800 Hz	$f = 300$ and 3400 Hz	-	± 0.2	-	dB
ΔG_{vT}	Gain Variation with Temperature Referenced to 25°C	without R6; $I_{line} = 50$ mA; $T_{amb} = -25$ and $+75^{\circ}\text{C}$	-	± 0.2	-	dB
DTMF input (pin 11)						
$ Z_i $	Input Impedance		-	20.7	-	K Ω
G_v	Voltage Gain from DTMF to LN	$I_{line} = 15$ mA; $R7 = 68$ K Ω	24.0	-	27.0	dB
ΔG_{vf}	Gain Variation with Frequency Reference to 800 Hz	$f = 300$ and 3400 Hz	-	± 0.2	-	dB
ΔG_{vT}	Gain Variation with Temperature Referenced to 25°C	$I_{line} = 50$ mA; $T_{amb} = -25$ and $+75^{\circ}\text{C}$	-	± 0.2	-	dB
Gain Adjustment Inputs GAS1 and GAS2 (pins 2 and 3)						
ΔG_v	Transmitting Amplifier Gain Variation by Adjustment of R7 between GAS1 and GAS2		-8	-	0	dB
Sending Amplifier Output LN (pin 1)						
$V_{LN(rms)}$	Output Voltage (RMS value)	THD = 10% $I_{line} = 4$ mA $I_{line} = 15$ mA	- 1.7	0.8 -	- -	V
$V_{no(rms)}$	Noise Output Voltage (RMS value)	$I_{line} = 15$ mA; $R7 = 68$ K Ω 200Ω between MIC- and MIC+	-	-69	-	dBmp
Receiving Amplifier Input IR (pin 10)						
$ Z_i $	Input Impedance		-	21	-	K Ω
Receiving amplifier output QR (pin 4)						
$ Z_o $	Output Impedance		-	4	-	Ω
G_v	Voltage Gain from IR to QR	$I_{line} = 15$ mA; $R_L = 300 \Omega$ (from pin 9 to pin 4)	29.5	-	32.5	dB

(continued)

ELECTRICAL CHARACTERISTICS ($I_{line} = 11$ to 140 mA; $V_{EE} = 0$ V; $f = 800$ Hz; $T_{amb} = 25^{\circ}\text{C}$; unless other specified)

Symbol	Parameter	Test Conditions	Guaranteed Limits			Unit
			Min	Typ	Max	
ΔG_{vf}	Gain Variation with Frequency Reference to 800 Hz	$f = 300$ and 3400 Hz	-	± 0.2	-	dB
ΔG_{vT}	Gain Variation with Temperature Referenced to 25°C	without R6; $I_{line} = 50$ mA; $T_{amb} = -25$ and $+75^{\circ}\text{C}$	-	± 0.2	-	dB
$V_{o(rms)}$	Output Voltage (RMS value)	THD = 2%; sine wave drive: $R_4 = 100$ K Ω ; $I_{line} = 15$ mA; $I_p = 0$ mA $R_L = 150$ Ω $R_L = 450$ Ω	0.22 0.3	- -	- -	V
$V_{o(rms)}$	Output Voltage (RMS value)	THD=10%; $R_4=100$ K Ω ; $I_{line} = 4$ mA; $R_L = 150$ Ω	-	15	-	mV
$V_{no(rms)}$	Noise Output Voltage (RMS value)	$I_{line} = 15$ mA; $R_4=100$ K Ω IR open-circuit psophometrically weighted; $R_L=300$ Ω	-	50	-	μV
Gain Adjustment Input GAR (pin 5)						
ΔG_v	Receiving Amplifier Gain Variation by Adjustment of R_4 between GAR and OR		-11	-	0	dB
Mute Input (pin 12)						
V_{IH}	HIGH Level Input Voltage		1.5	-	V_{CC}	V
V_{IL}	LOW Level Input Voltage		-	-	0.3	V
I_{MUTE}	Input Current		-	-	15	μA
Raduction of Gain						
ΔG_v	MIC+ or MIC- to LN	MUTE = LOW	-	70	-	dB
G_v	Voltage Gain from DTMF to QR	$R_4 = 100$ K Ω $R_L = 300$ Ω	-	-17	-	dB
Automatic Gain Control Input AGC (pin 15)						
ΔG_v	Controlling the Gain from IR to QR and the Gain from MIC+, MIC- to LN Gain Control Range	$R_6 = 110$ K Ω (between AGC and V_{EE}) $I_{line} = 70$ mA	-	-5.8	-	dB
I_{lineH}	Highest Line Current for Maximum Gain		-	23	-	mA
I_{lineL}	Lowest Line Current for Minimum Gain		-	61	-	mA

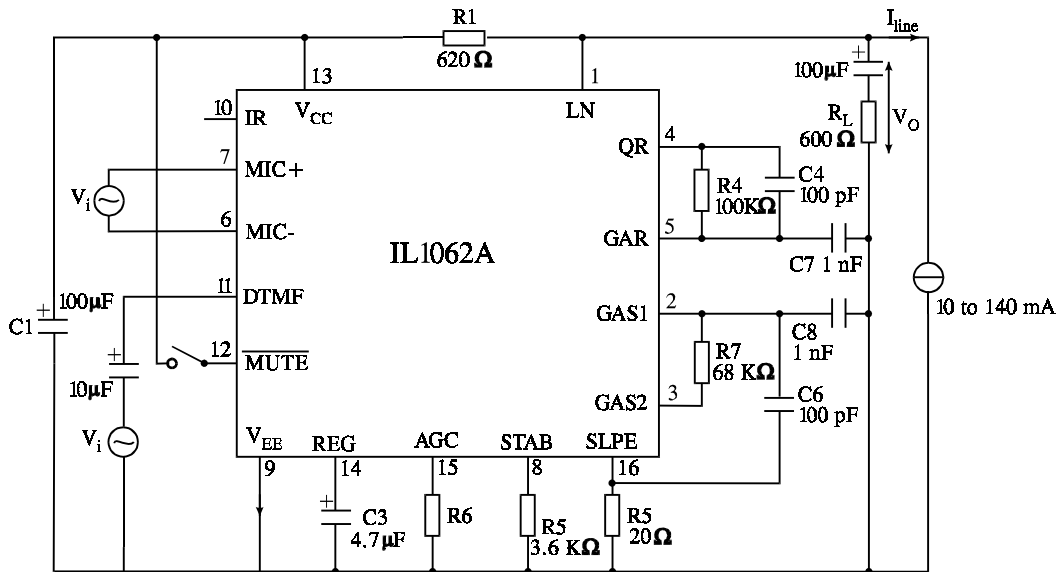

Voltage gain is defined as $G_v = 20 \log \frac{V_o}{V_i}$

For measuring gain from MIC+ and MIC- the MUTE input should be HIGH.
 For measuring the DTMF input, the MUTE input should be LOW or open-circuit.
 Inputs not being tested should be open-circuit.

Figure 3. Test circuit for defining ILA1062A voltage gain of MIC+, MIC- and DTMF inputs.

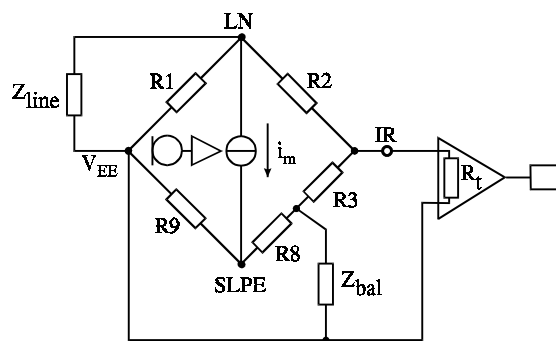
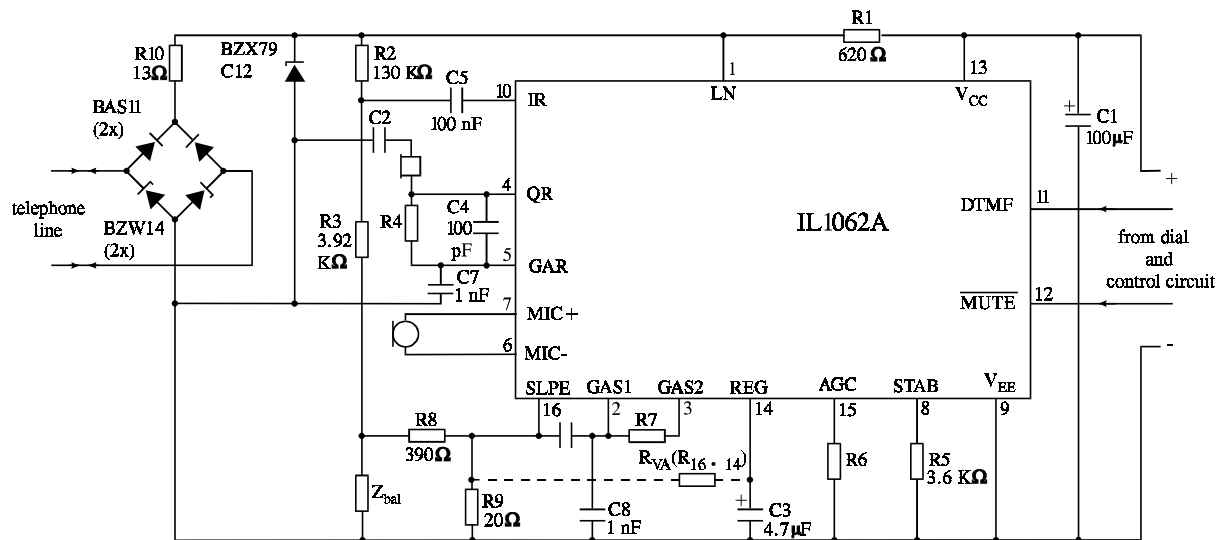

Figure 4. Equivalent circuit of ILA1062A anti-sidetone bridge



The diode bridge, the Zener diode and R10 limit the current into, and the voltage across, the circuit during line transients.

A different protection arrangement is required for pulse dialling or register recall.

The DC line voltage can be set to a higher value by the resistor R_{VA} (REG to SLPE).

Figure 5. Typical application of ILA1062A, with piezo-electric earpiece and DTMF dialling.