

P/N
CCSF

REVISIONS				
ZONE	REV.	DESCRIPTION(S)	DATE	BY
-	A	ECO 19560	09.08.06	DKN

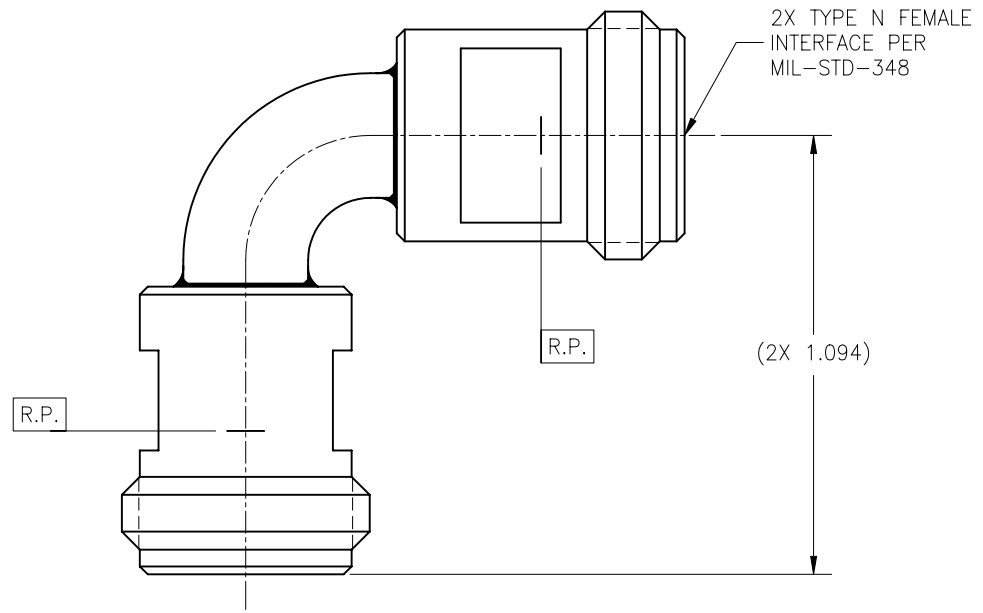

DRAWING NO.	8029	REV.	A
-------------	------	------	---

MATERIAL:	ELECTRICAL:	MECHANICAL:	ENVIRONMENTAL:
Body & Insert: 303 sst per ASTM A-582. Center Conductor: BeCu alloy per ASTM B-196. Dielectric: PTFE per ASTM D-1710.	Impedance: 50 Ohms nominal. Frequency Range: DC to 18.0 GHz. VSWR: 1.25:1 max to 18.0GHz. Insertion Loss: .15 dB max to 18.0GHz. Working Voltage: 500Vrms @ Sea Level 125Vrms @ 70,000 ft Dielectric Withstand Voltage: 1500 Vrms RF HiPot Withstand Voltage: 1000 Vrms Corona Level: 375 Vrms Min. Insulation Resistance: 5000 MegaOhms Contact Resistance: Center Conductor: 2.5 mOhms MAX Outer Conductor: 0.2 mOhms MAX Permeability: Less than 2.0 MU	Mating Characteristics: Interface per Mil-Std-348. Center Contact Retention: Axial Force: 6 pounds min. Connector Durability: 500 cycles min @ 12 cycles/minute max.	Temperature Range: -65°C to +165°C. Moisture Resistance: Mil-Std-202, Method 106, Insulation resistance at least 200 MegOhms within 5 minutes after removal from humidity. Corrosion: Mil-Std-202, Method 101, Test Cond. B. Mil-Std-202, Method 204, Test Cond. B. Vibration: Mil-Std-202, Method 213, Test Cond. I. Shock:

FINISH:
Body And Coupling Nut: Passivate per ASTM A-967. Center Conductor: Gold plate per ASTM B-488, over nickel under plate per AMS-QQ-N-290.

APPLICABLE TENSOLITE DOCUMENTS		
WORK STD	PROD INST	ASSY INST
NA	NA	NA

NOTICE

THIS DRAWING EMBODIES A CONFIDENTIAL PROPRIETARY DESIGN ORIGINATED BY TENSOLITE COMPANY AND ALL DESIGN, MANUFACTURING REPRODUCTION, USE AND SALE RIGHTS REGARDING THE SAME ARE EXPRESSLY RESERVED. IT IS SUBMITTED UNDER A CONFIDENTIAL RELATIONSHIP FOR A SPECIFIED PURPOSE AND THE RECIPIENT AGREES BY ACCEPTING THIS DRAWING NOT TO SUPPLY OR DISCLOSE ANY INFORMATION REGARDING IT TO ANY UNAUTHORIZED PERSON TO INCORPORATE IN OTHER PROJECTS ANY SPECIAL FEATURES PECULIAR TO THIS DESIGN. ALL PATENT RIGHTS HERETO ARE EXPRESSLY RESERVED BY TENSOLITE COMPANY, LONG BEACH, CALIFORNIA 90815.

TOLERANCES AND NOTES EXCEPT AS NOTED	
DIMENSIONS ARE IN INCHES.	
LINEAR	.XX ±.015 ANGULAR ± 1/2°
FRACTION	± 1/32
1. MACHINE FINISH:	√ RMS
2. BREAK ALL SHARP EDGES	.003 MAX.
3. MACHINED FILLETS	.005 MAX.
4. MACHINED SURFACES SQUARE TO RESPECTIVE AXIS WITHIN .005 INCHES PER INCH.	
5. MACHINED DIAMETERS CONCENTRIC WITHIN .002 T.I.R.	
6. DIMENSIONS TO BE MET BEFORE PLATING.	
7. CHAMFER ALL THREADS 45°.	
8. THREADS PER H-28	
9. REMOVE FRAYED EDGES ON TEFLON.	
10. REMOVE ALL BURRS.	

MATERIAL		SIZE		SPECIFICATION		PROCUREMENT	
NEXT ASSY		TITLE		HIGH PERFORMANCE CABLES & INTERCONNECT SYSTEMS Long Beach, California 90815			
APPROVAL INITIALS		DATE		TYPE N FEMALE TO TYPE N FEMALE RADIUS R/A ADAPTER			
DRAWN BY	DKN	09.08.06		Tensolite			
CHECKED				SUB-DIRECTORY \FILENAME			
QUALITY		SCALE		SHEET 1 of 1			
		5:1		OL_\			
ENGINEERING	ATV	09.13.06		SIZE		DRAWING NO.	
				C 30990		8029	
						REV. A	